

# HIGH-EFFICIENCY COMMERCIAL FRONT-LOAD WASHER



Featuring Factory-Installed Coin Slide and Coin Box



## CHW9050AW—27" Washer with Metercase

Machine Accepts the Following Compatible Payment Systems:

- Coin Slide
- Coin-Drop
- Card Reader
- Non-Coin Payment Configurations
- 3.1-Cu.-Ft. Wash Basket
- Push-Button Controls
- High-Efficiency, Low Water Usage
- Combination of 9 Cycle Options
- Variable Speed Motor for Best Cleaning Performance

- Front Control Panel 22° Angle
- Automatic Water Level Control
- 130° Door Opening with Heavy-Duty Die-Cast Hinges
- High-Speed Spin Helps Reduce Dry Time
- Removable Front Service Panel
- Commercial Grade Water Inlet Hoses with Brass Couplings
- 2-Year Limited Parts Only Warranty/90-Day Labor\*

\*Call 1-800-NO-BELTS (800-662-3587) for warranty details.

## HIGH-EFFICIENCY DESIGN OFFERS SIGNIFICANT UTILITY SAVINGS

- ENERGY STAR®-Qualified
- CEE Tier II
- Modified Energy Factor: 2.3
- Water Factor: 4.23

## LARGE-CAPACITY WASH BASKET

- Ideal for Handling Family-Size Loads
- 130° Door Opening with Heavy-Duty Die-Cast Hinges

## INDUSTRIAL GRADE CABINET

- Top with Integrated Backsplash
- Resists Chipping and Scratching

## LARGE-CAPACITY METERCASE

- Large Coin Box for Reduced Collections
- Accepts Coin Slide, Coin-Drop, Card Reader and Non-Coin Payment Configurations

## MICROPROCESSOR CONTROLS

- Time Remaining Display
- Front Controls for Ease-of-Use
- Card Reader Compatible

## AUTOMATIC DETERGENT, SOFTENER AND BLEACH DISPENSER

## SOFT-MOUNT DESIGN FOR EASY INSTALLATIONS

## INDUSTRIAL STRENGTH WATER INLET HOSES

# HIGH-EFFICIENCY COMMERCIAL FRONT-LOAD WASHER



Featuring Factory-Installed Coin Slide and Coin Box

## Whirlpool® High-Efficiency Commercial Front-Load Washer

WASHER SPECIFICATIONS	
<b>MODEL</b>	CHW9050AW
<b>MOTOR</b>	
Variable speed, reversible, thermoprotected, high-efficiency controlled induction	Yes
Wash — HP (kWh)	.09 (.07)
Extract — HP (kWh)	.54 (.40)
Average kilowatt hour per cycle	0.07
<b>ELECTRICAL REQUIREMENTS</b>	
Domestic model — Voltage	120V/60Hz
<b>BREAKER/FUSE REQUIREMENTS</b>	
Domestic Amps	15
<b>CAPACITY</b>	
Volume — cu. ft. (liters)	3.1 (88)
Diameter — in. (mm)	21.6 (547)
Depth — in. (mm)	13.4 (341)
<b>DOOR OPENING</b>	
Sq. In.	143
<b>WASH SPEED</b>	
RPM	31–40
<b>EXTRACT SPEED</b>	
Maximum RPM	832
Maximum g-force	214
<b>OPERATING PRESSURE</b>	
Psi (bar)	20–100 (1–8)
<b>INLET HOSE</b>	
Ft. (m)	4 (1.22)
<b>DRAIN HOSE</b>	
Ft. (m)	6 (1.83)
<b>ADJUSTABLE LEVELING LEGS</b>	Yes
<b>APPROXIMATE WEIGHT</b>	
Crated — lbs. (kg)	254 (115)
Uncrated — lbs. (kg)	245 (111)
<b>DIMENSIONS</b>	
Width — in. (mm)	27 (686)
Depth — in. (mm)	29.25 (743)
Height — in. (mm)	45.67 (1160)*

\*Height at metercase top does not include optional pedestal.  
See specific instructions for proper installation. Because of continuous product improvement, Whirlpool reserves the right to change specifications without notice.  
Pedestal Single Box Kit #WHP0400VW Pedestal Pack of 10 Kit #WHP0401VW

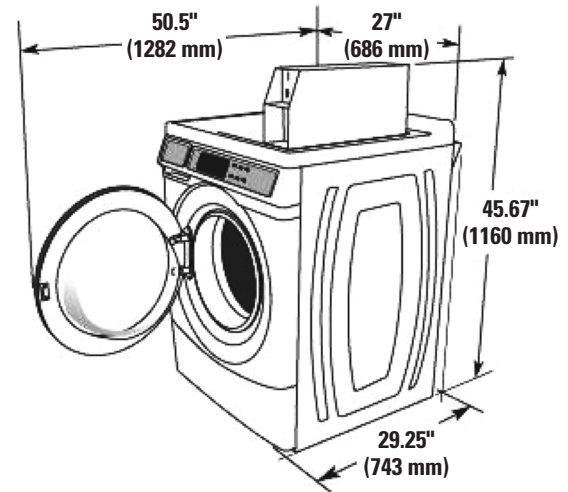

Dimensions are for planning purposes only. See Whirlpool® Installation Instructions for full details.



### 2-YEAR LIMITED PARTS ONLY WARRANTY

For the first two years from the date of purchase, when this major appliance is installed, maintained and operated according to the instructions attached to or furnished with the product, Whirlpool will pay for factory-specified replacement parts to correct defects in materials or workmanship that existed when this commercial appliance was purchased. See complete warranty for details.



To Locate a Distributor Near You, Please Visit [www.whirlpoolcommerciallaundry.com/distributor](http://www.whirlpoolcommerciallaundry.com/distributor), or Call 1-800-N0-BELTS.