

HIGH-EFFICIENCY COMMERCIAL WASHER



Full-Feature Metered Compatible



CHW8990CW 27" Washer With Metercase

Machine Accepts the Following
Compatible Payment Systems:

- Coin Slide
- Coin-Drop
- Card Reader
- Non-Coin Payment Configurations
- 3.1 Cu. Ft. Wash Basket
- Push-Button Controls
- High-Efficiency, Low Water Usage
- Combination of 9 Cycle Options
- Variable Speed Motor for Best Cleaning Performance

- Front Control Panel 22° Angle
- Automatic Water Level Control
- 180° Door Opening with Heavy-Duty Die-Cast Hinges
- High-Speed Spin—Reduces Dry Time
- Removable Front Service Panel
- Commercial Grade Water Inlet Hoses with Brass Couplings
- **3-Year Limited Parts Only Warranty***
- Money Acceptors Sold Separately

*Call 1-800-NO-BELTS (800-662-3587) for warranty details.

LARGE CAPACITY WASH BASKET

- Ideal for Handling Family-Size Loads
- 180° Door Opening with Heavy-Duty Die-Cast Hinges

INDUSTRIAL GRADE CABINET

- Porcelain-Finish Top with Integrated Backsplash
- Resists Chipping and Scratching

LARGE CAPACITY METERCASE

- Larger Coin Box for Reduced Collections
- Accepts Coin Slide, Coin-Drop, Card Reader and Non-Coin Payment Configurations

MICROPROCESSOR CONTROLS

- Time Remaining Display
- Front Controls for Ease-of-Use
- Card Reader Compatible
- Time of Day Pricing
- Cycle-Based Pricing

AUTOMATIC DETERGENT, SOFTENER AND BLEACH DISPENSER

HIGH-EFFICIENCY DESIGN OFFERS SIGNIFICANT UTILITY SAVINGS

- ENERGY STAR®-Qualified
- CEE Tier II



SOFT-MOUNT DESIGN FOR EASY INSTALLATIONS

INDUSTRIAL STRENGTH WATER INLET HOSES

ADA-COMPLIANT WITH OPTIONAL PEDESTAL

HIGH-EFFICIENCY COMMERCIAL WASHER



Full-Feature Metered Compatible

Whirlpool® High-Efficiency Front-Load Commercial Washer Coin-Drop Ready

WASHER SPECIFICATIONS	
MODEL	CHW8990CW
MOTOR	
Variable speed, reversible, thermoprotected, high-efficiency controlled induction	Yes
Wash — HP (kWh)	.09 (.07)
Extract — HP (kWh)	.54 (.40)
Average kilowatt hour per cycle	0.07
ELECTRICAL REQUIREMENTS	
Domestic model — Voltage	120V/60Hz
BREAKER/FUSE REQUIREMENTS	
Domestic Amps	15
APPROXIMATE WATER USAGE—GALLONS (LITERS)	
Average total water usage per cycle	13.28 (50.3)
CAPACITY	
Volume — cu. ft. (liters)	3.1 (88)
Diameter — in. (mm)	21.6 (547)
Depth — in. (mm)	13.4 (341)
DOOR OPENING	
Sq. In.	143
WASH SPEED	
RPM	31–40
EXTRACT SPEED	
Maximum RPM	832
Maximum g-force	214
OPERATING PRESSURE	
Psi (bar)	20–100 (1–8)
INLET HOSE	
Ft. (m)	4 (1.22)
DRAIN HOSE	
Ft. (m)	6 (1.83)
ADJUSTABLE LEVELING LEGS	Yes
APPROXIMATE WEIGHT	
Crated — lbs. (kg)	254 (115)
Uncrated — lbs. (kg)	245 (111)
DIMENSIONS	
Width — in. (mm)	27 (686)
Depth — in. (mm)	29.25 (743)
Height — in. (mm)	45.67 (1160)*
*Height at metercase top does not include pedestal. See specific instructions for proper installation. Because of continuous product improvement, Whirlpool reserves the right to change specifications without notice. Power cords on electric models sold separately. Pedestal Single Box Kit #WHP0400VW Pedestal Pack of 10 Kit #WHP0401VW	

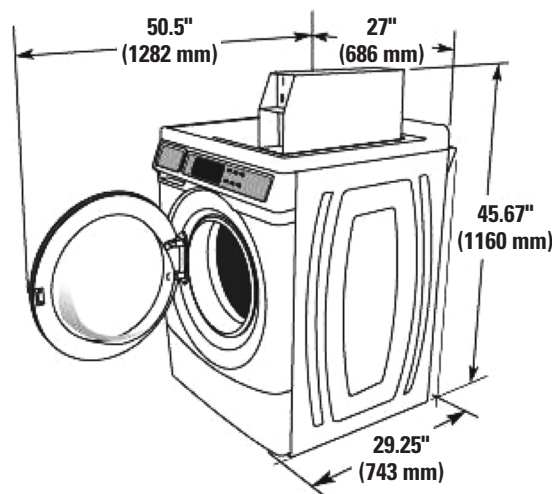

Dimensions are for planning purposes only.
See Whirlpool® Installation Instructions for full details.



NEW YORK CITY
M.E.A.



3-YEAR LIMITED PARTS ONLY WARRANTY

For a period from the date of original purchase through the time listed above, the designated parts that fail in normal commercial use will be repaired or replaced free of charge for the part itself, with the owner paying all other costs, including labor, transportation and customs duty. Chemical damage is excluded from all warranty coverage. See complete warranty for details.



To Locate a Distributor Near You, Please Visit www.whirlpoolcommerciallaundry.com/distributor, or Call 1-800-N0-BELTS.