



T9 TUMBLE DRYER



RADIAL AND AXIAL AIRFLOW
For maximal heat transfer, low energy consumption and short drying time



ECO VERSION
All dryers are available with reduced kW heating element



CLOUD - BASED PLATFORM
to easily monitor your laundry everywhere and at any time



EXTRA LARGE DOOR OPENING
For easy loading and unloading



IMPROVED DURABILITY
for your peace of mind with a 3 - year warranty

FEATURES & BENEFITS

Features

- Standard galvanized drum with large diameter
- Large door opening for easy loading & unloading

Options

- Coin operated
- Stainless steel front
- Reversing drum
- Double door glass and insulation
- Residual moisture control Sensodry:
 - safe drying of delicate linen
 - humidity detection in %
 - ideal in combination with SoftWash®
 - ideal for dry cleaners, fire depts
 - available on Easy and Full Control
- WiFi kit - to order through Accessories

Control

- Easy - To - Use Microprocessor (ECT) - intuitive control with simple selection of 3 programs
- Full Control Programmer (FCT) - fully programmable timer with possibility of residual moisture control

SPECIFICATIONS

TYPE		T9
CAPACITY		
Capacity 1:18	kg (lb)	9(20)
Capacity 1:22	kg (lb)	8(18)
Drum volume	l	190
Drum diameter	mm	Ø 760
AIRFLOW		
	m ² /h	350
DRYING AVERAGE		
	l/min.	0,150
MOTORS		
Fan	kW	0,37
Drive	kW	0,18
GAS HEATING		
Gas connection	inch	1/2"
Electrical connection		3x380 - 415V 50/60Hz, 3x220 - 240V 50Hz 3x208 - 240V 60Hz, 3x440V 60Hz
Energy	kW	12,5
	kBTU/h	42,7
ELECTRICAL HEATING		
Electrical connection		3x380 - 415V 50/60Hz 3x220 - 240V 50Hz 3x208 - 240V 60Hz, 3x440V 60Hz 3x480V 60Hz
Energy	kW	9/12
EXHAUST		
	mm	Ø 200
DIMENSIONS		
H×W×D	mm	1465x795x815
Net weight	kg	170
TRANSPORT DATA		
Packed H×W×D	mm	1570x880x885
Gross weight	kg	180

The data concerning dimensions of machines include all extended parts

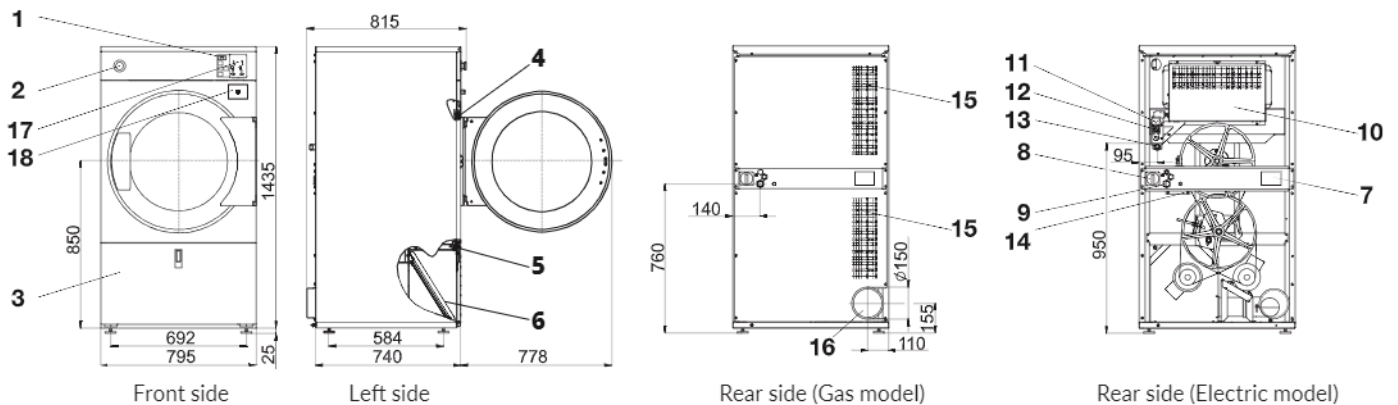

- | | | |
|---|--|--|
| 1. Programmer | 7. Name plate | 14. Airflow switch |
| 2. Emergency stop button (not applicable for version with coin meter) | 8. Main switch | 15. Suction |
| 3. Lint screen cover | 9. Main power supply | 16. Exhaust piping |
| 4. Door lock microswitch | 10. Heating chamber | 17. Coin meter (version with coin meter) |
| 5. Lint cover microswitch | 11. Gas valve (G models only) | 18. Coin box (version with coin meter) |
| 6. Lint screen | 12. Pressure regulator (G models only) | |
| | 13. Gas supply (G models only) | |