



Commercial Front-Load Washer

With 100 years of experience in the industry and features that streamline service, Whirlpool® Commercial Laundry machines provide performance with the quality you expect.

Featuring Factory-Installed Coin Drop and Coin Box

Commercial-Grade Features:

Choose a commercial-built product that withstands heavy traffic, regular use, and performs continuously.



Commercial-Grade Cabinet with Porcelain-Enamel Top

Built from heavy, galvanized steel, this cabinet is designed to keep up with traffic in a commercial laundry space.



Drive System

The powerful drive system was designed and tested to provide more turns over the life of the washer, giving your customers the performance they expect over time.



Automatic Load Balancing

A six-point suspension with four dampers and two springs helps deliver consistent cycle times and optimal unbalanced performance.

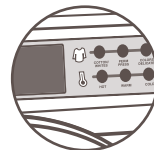

Microprocessor Controls

Controls offer owners the ability to customize vend prices and washer cycle options, such as Super Cycle, ensuring optimal revenue opportunities. Controls also give customers the option to select the ideal cycle for individual wash needs.



High-Efficiency Design

Helps reduce energy and water costs. Washer is ENERGY STAR®-Qualified and CEE Tier II rated.

CHW9150GW — 27" High-Efficiency Commercial Washer

- 3.1-cu.-ft. Large Capacity Wash Basket
- High Efficiency, Low Water Usage
- Variable Speed Motor for Better Cleaning Performance
- Super Cycle Offers Three Extra Minutes of Wash Time or an Additional Rinse
- 1,000-RPM Spin Speed Helps Reduce Dry Time
- 135° Door Opening with Heavy-Duty Die-Cast Hinges

- Removable Front Service Panel
- Water Inlet Hoses Included
- Factory Coin Drop and Coin Box Equipped
- 90-Day Labor/2-Year Limited Parts Only Warranty*

*See whirlpoolcommerciallaundry.com for complete warranty details.

Commercial Front-Load Washer

Featuring Factory-Installed Coin Drop and Coin Box



Washer Specifications

Model	CHW9150GW
Motor Size HP (kw)	.09 (.07)
Modified Energy Factor (MEF)	2.2
Water Factor (WF)	4
Approximate Water Usage—Gallons (Liters)	
Average total water usage per cycle	12.24 (46.33)
Average hot water usage warm water cycle	1.5 (5.67)
Average hot water usage hot water cycle	2.28 (8.63)
Extract Speed—Max G-Force / Max RPM	300/1,000
Capacity	
Cylinder volume—cu. ft. (liters)	3.1 (88)
Cylinder diameter—in. (mm)	21.6 (547)
Cylinder depth—in. (mm)	13.4 (341)
Dimensions	
Width—in. (mm)	27 (686)
Depth—in. (mm)	28.8 (732)
Height—in. (mm)	44.62 (1,134)**
Door opening—in. (mm)	14.25 (362)
Crated Dimensions	
Width—in. (mm)	29 (737)
Depth—in. (mm)	33.5 (851)
Height—in. (mm)	48.5 (1,232)
Approximate Weight	
Uncrated—lbs. (kg)	245 (111)
Crated—lbs. (kg)	254 (115)
Electrical Requirements	
Electrical rating—voltage/HZ	120/60
Breaker/Fuse—amps	15
Water Inlet/Hose	
Operating pressure PSI (bar)	20–100 (1–8)
Inlet hose length—ft. (m)	4 (1.22)
Drain hose length—ft. (m)	6 (1.83)
Warranty	2-Year Limited/90-Day Labor

**Includes height of metercase.

Dimensions are for planning purposes only. See specific instructions for proper installation. Because of continuous product improvement, Whirlpool reserves the right to change specifications without notice.

ADA-compliant (with optional pedestal).

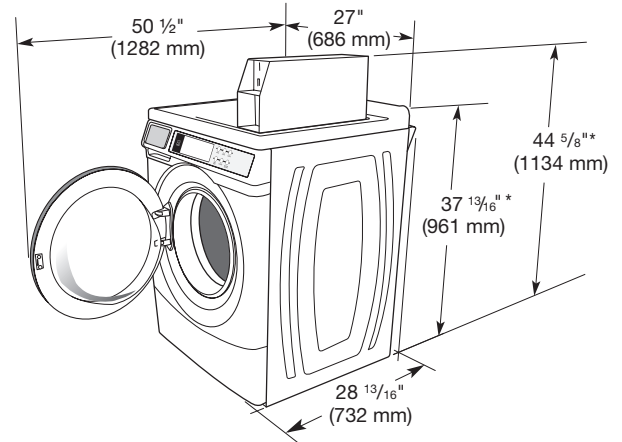

*Height without leveling feet installed.



2-YEAR LIMITED PARTS ONLY WARRANTY/90-DAY LABOR

For 90 days from the date of original purchase, when this commercial appliance is installed, maintained and operated according to instructions attached to or furnished with the product, Whirlpool Corporation (hereafter "Whirlpool") will pay for factory-specified replacement parts and repair labor to correct defects in materials or workmanship that existed when this commercial appliance was purchased. For the first two years from the date of purchase, when this major appliance is installed, maintained and operated according to the instructions attached to or furnished with the product, Whirlpool will pay for factory-specified replacement parts to correct defects in materials or workmanship that existed when this commercial appliance was purchased.